



OFFSHORE



LAND RIG

Safety & Maintenance of Gates Rotary & Vibrator Hoses

Forward

The objective of this manual is to emphasize SAFETY by providing recommended procedures for proper handling, storage, use and maintenance of rotary drilling and vibrator hose assemblies. External inspection and field pressure testing prior to any continued service of a hose assembly is critical to ensure safe operation. These are MANDATORY PROCEDURES for applications where an assembly failure could result in serious bodily injury or severe property damage.

Scope

This procedure is a recommended practice for the storage, handling, operations, testing and inspection of flexible connectors.

This includes connectors between the standpipe and swivel (A: Rotary Drilling Hose) as well as connectors between the pump and standpipe (B: Vibrator Hose) for pumping mud at high pressures during oil drilling and exploration work (see Figure 1).

This applies to hoses having inside diameters of up to 4" with API grade classifications D and E.

Warning

A failure of a rotary drilling or vibrator hose in service may result in serious bodily injury or severe property damage.

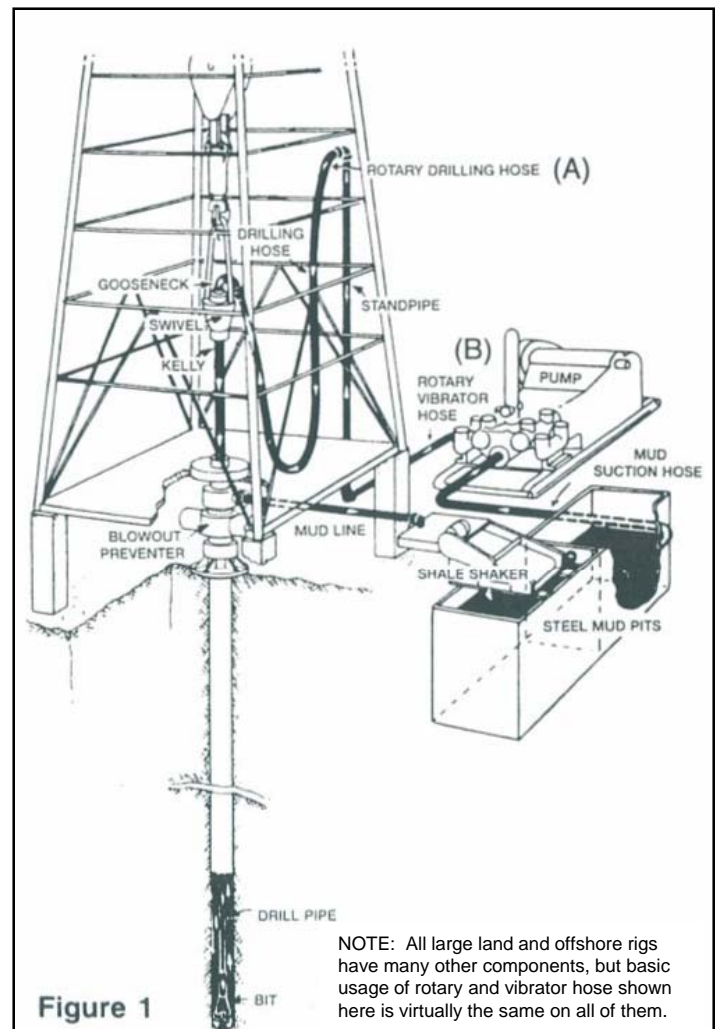



OFFSHORE



LAND RIG

Safety & Maintenance of Gates Rotary & Vibrator Hoses

Storage

1. Completely drain hose assembly before placing in storage.
2. Whenever feasible, store hose in original shipping crate. This will provide extra protection against the deteriorating effects of solvents, corrosive liquids, ozone and sunlight. Hose should be stored so coils are in a horizontal plane.
3. Certain rodents and insects can damage hose. Adequate protection from them should be provided too.
4. The ideal temperature for storing hose ranges from 50° F (10° C) to 70° F (21° C) with a maximum limit of 100° F (38° C). If stored below 32° F (0° C), hose will become stiff and will require warming before being placed in service. Hose should not be stored near sources of heat, such as radiators or base heaters.
5. To avoid adverse affects of high ozone concentrations, hose should not be stored near electrical equipment that may generate ozone or be stored for any lengthy period in geographical areas with high concentrations of ozone. Exposure to sunlight, direct, reflected or even through windows should be avoided.
6. Do not stack hose or place anything heavy on top of it to prevent damage.

Handling

Caution: Care should be exercised to prevent mishandling. Crushing or kinking of hose can cause severe damage to reinforcement. If this occurs, remove hose from service.

1. In order to minimize the chance of kinking, hose should preferably be removed from its crate by hand, laid out in a straight line, then lifted by means of a catline attached near one end of hose.
2. Hose assemblies should never be lifted by the safety clamp and chain. The assembly should always be lifted by the lift eye clamps (see figures 2 and 5).
3. Attachment of a set of lift eye clamps to the hose end coupling to safely lift and move a heavy rotary hose assembly is a **necessity** to avoid hose kink damage. A set of lift eye clamps can be obtained on special order (see Figure 2).

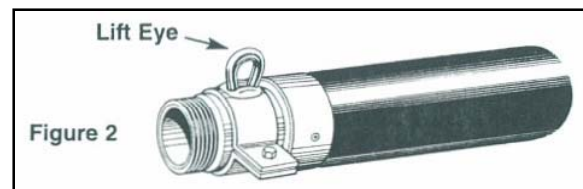



OFFSHORE



LAND RIG

Safety & Maintenance of Gates Rotary & Vibrator Hoses

Recommended Practices

Where applicable, the following recommended practices should be used on rotary drilling and vibrator hose.

A. Overall Hose Length

1. Includes standard connector and/or special adapters (see Figure 3).

B. Rotary Hose Length

1. In order to avoid kinking hose, the hose length and standpipe height should be such that when raising or lowering, as in making mousehole connections, the hose will have a normal bend radius at the swivel when it is at its lowest drilling position and at the standpipe when it is at its highest drilling position. Use the following equation to determine the recommended hose length.

$$L_H = L_T/2 + \pi R + S$$

Where:

L_H = Length of hose in ft.

L_T = Length of hose travel in ft.

R = Minimum bend radius in ft.

= 4' for 2 1/2" and 3" hose

= 4.5' for 3 1/2" and 4" hose

S = Allowance for contraction in L_H due to maximum recommended working pressure in ft., which is 1 ft. for all sizes.

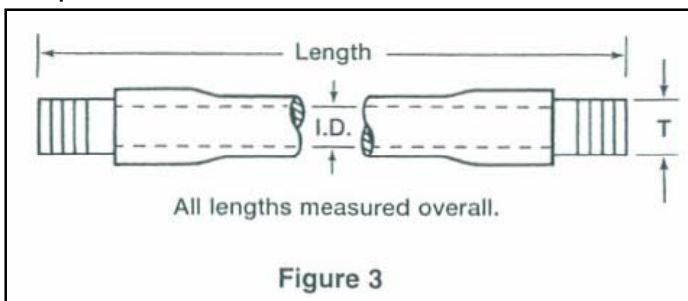

Figure 3

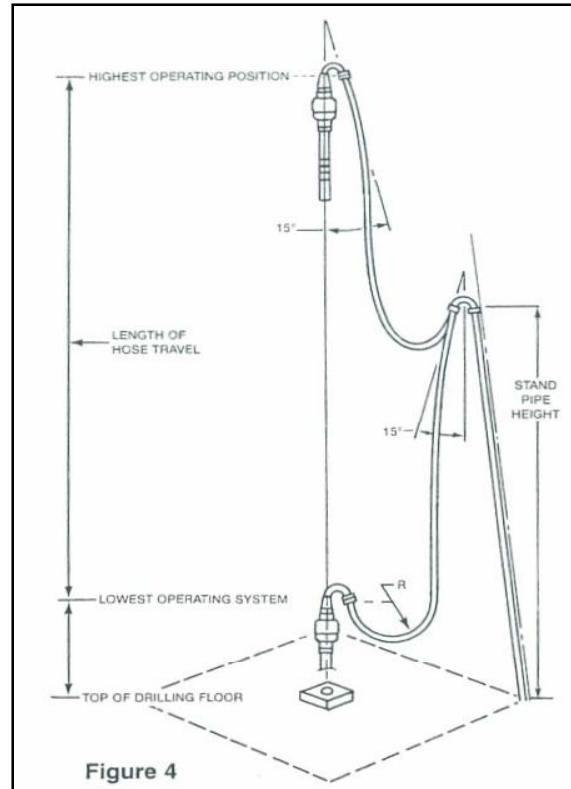

Figure 4

C. Standpipe Height

1. Use the following equation to determine the recommended standpipe height (see Figure 4).

$$H_S = L_T/2 + Z$$

Where:

H_S = Vertical height of standpipe in ft.

L_T = Length of hose travel in ft.

Z = Height in ft. from top of derrick floor to end of hose at swivel when swivel is at its lowest drilling position.

NOTE: When the actual hose length is greater than the calculated length, the standpipe height should be increased by half the difference between the actual length and calculated height.



OFFSHORE



LAND RIG

Safety & Maintenance of Gates Rotary & Vibrator Hoses

D. Vibrator Hose Length

1. It's important to choose a vibrator hose having an inside diameter equal to that of the pump discharge fitting and the fluid supply line inside diameters. This is necessary to allow free flow of fluid and to avoid turbulence or unnecessary abrasion of the hose tube. The length of vibrator hose should be given careful consideration. It should be long enough to prevent kinks near the couplings, yet short enough to prevent kinks in the radius near the middle of the hose.

E. Hose Connections

1. Line pipe threads should only be used on working pressure of 5,000 psi or less. Threaded end connections should not be welded to the coupling as this will damage hose. Working pressure of 5,000 psi and above should have end connections butt welded to the coupling. The connections attaching the hose to the swivel and standpipe should be as tangential as possible. The use of a standard connection on the swivel gooseneck will ensure this relationship at top of hose. It's recommended that a 180 degree gooseneck be used on the standpipe connection if the standpipe is vertical. A 160 degree gooseneck should be used if the standpipe has the same slope as the derrick leg.

F. Vibration and Pulsation

1. Continuous pressure pulsations and vibrations may shorten the useful life of rotary and vibrator hoses used in high pressure mud piping systems. Surge chambers or pulsation dampeners of

the proper size should be installed in each mud pump discharge line to minimize pulsations and vibrations in the mud lines and hoses. The precharge pressure for pulsation dampeners should be set at 10 percent of the maximum pump pressure. The lines on the suction side of the pump should be pressure charged or operated with a flooded suction to minimize cavitation that can cause pulsations. Pulsation dampeners designed for the pump suction lines should also be installed to minimize pulsation if cavitation occurs.

G. Operating Limits.

1. Operating personnel should be advised as to the highest and lowest drilling positions, length of standpipe, etc., for which the hose was selected. Drilling operations should be carried out within such limits.

H. Clearance

1. Hose installation should allow adequate clearance between hose and derrick or mast.

I. Barge Attended Off-Shore Rigs

1. When rotary hose is used as a flexible line between barges or off-shore drilling rigs, care must be used so hose is in alignment between both end connections. It's recommended that swivel joints be used at both ends. Drilling in rough water and high seas, resulting in excessive flexing and jerking of hose, will cause premature failure.



OFFSHORE



LAND RIG

Safety & Maintenance of Gates Rotary & Vibrator Hoses

Operations

Caution: Care should be exercised during operation to prevent crushing or kinking of hose. Crushing or kinking can cause severe damage to cable reinforcement. If this occurs, remove hose from service and test as outlined in the "Field Test Pressure" section.

A. Working Temperature

- Working temperature should not exceed 180°F (82°C).
Temperatures encountered higher than 180°F (82°C) will shorten the useful life of the hose.

B. After Coolers

- Compressors should always be equipped with after coolers to lower the air or gas temperatures within tolerable limits. If after coolers are not used, air or gas entering hose at excessively high temperatures can accelerate the hose aging rate, thus reducing the expected service life.

C. Working Pressure

- The recommended maximum working pressure for rotary hose is shown in Table 1. Working pressure includes the pressure surges that occur in the system.

HOSE I.D. (In.)	Available Grades	Working Pressures (psi)	
		Grade D	Grade E
2 1/2	D, E	5,000	7,500
3	D, E	5,000	7,500
3 1/2	D, E	5,000	7,500
4	D, E	5,000	7,500

D. Oil Base Muds

- The use of oil base muds having an excessively high aromatic content will cause hose inner liner to swell, resulting in less abrasion resistance which can shorten service life. It's recommended that oil base muds be held to a minimum aniline point of 150°F (66°C).

E. Twisting

- Hose should not be intentionally back twisted. In order to prevent twisting, it's suggested that a swivel be installed on the gooseneck end of hose. Each length of hose has a yellow longitudinal stripe. Use this as a guide to ensure hose is installed without any twist.

F. Safety Clamps (see Figure 5)

- All rotary hoses and vibrator hoses 8' or longer are marked with the notation "Attach Safety Clamp Here". Safety clamps must be installed prior to placing hose into service.
 - For rotary hose — This dimension shall be 6" to 18" from the inboard end of the coupling.
 - For vibrator hose — This dimension shall be 6" to 10" from the inboard end of the coupling.

- A set of safety clamps can be obtained on special order. The location for attaching these safety clamps is shown by marks at each end of the assembly. Lift eye/clamps are also available. Do not use the safety clamp or chain for lifting (see Figure 5).



OFFSHORE



LAND RIG

Safety & Maintenance of Gates Rotary & Vibrator Hoses

Operations Cont.

3. The safety clamp should be tightened securely, but not to such an extent as to damage hose or reduce the inside bore diameter. In the case of rotary hose, the safety chain should be attached to a derrick upright at the standpipe end, rather than a transverse support, so the chain will be free to move upward without restricting movement of the hose, should the traveling block be raised too high.

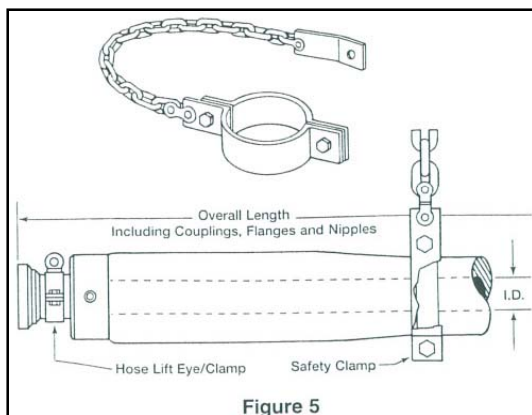

Figure 5

Field Test Pressure

Hose assemblies subjected to abnormal abuse such as severe end pull, flattening, crushing, sharp kinking or excessive pressurization must be immediately inspected and hydro-statically tested at 1.25 times the rated working pressure. Follow steps 4 through 9 below.

Field testing of rotary hose, when required for establishing periodic safety levels of continued operation, should be conducted with these factors as a guide:

1. Check and properly attach safety clamp and chain for complete safety compliance.

2. Avoid all back twist.
3. Suspend hose in normal unstressed position from standpipe to swivel.
4. Visually inspect hose for any external damage to hose body, end structure or couplings.
5. Raise pressure between 1,000 and 10,000 psi per minute.
6. Bleed air when using mud, oil or water as permissible test media.
7. Restrict duration of test pressure to a maximum of 10 minutes.
8. Do not exceed 1.25 times the maximum rated working pressure when testing.
9. Conduct field testing under full responsibility of end user with SAFETY in mind.

External Inspection

1. Carefully examine hose cover prior to each rig-up or every 30 days, whichever comes first.
2. Hose cover serves the primary function of protecting cable reinforcement from physical or environmental damage. Cover should be carefully examined to detect areas where cable reinforcement may have been damaged. Inspect hose cover for cuts, gouges, tears and abrasion.
3. Any cuts, gouges or tears in the cover down to, but not into cable reinforcement should be regularly



OFFSHORE



LAND RIG

Safety & Maintenance of Gates Rotary & Vibrator Hoses

External Inspection Cont.

inspected to ensure further deterioration does not occur. If cable reinforcement is exposed and rust or corrosion is evident, remove hose from service.

4. Cover may show surface cracking due to prolonged exposure to sunlight or ozone. Such deterioration, as long as it does not expose the cable reinforcement, is not usually cause for removal from service.

On-The-Job Welding

CAUTION: On-the-job welding of hose assemblies is not recommended. Excessive heating from welding can cause hose damage.

Warranty

Black Gold[®] oil field hoses are warranted by Gates Corporation to be free from defects in material and workmanship for the life of the product. Should a defect be proven in the product's material or workmanship, Gates will, at its option, replace or repair any rotary drilling or vibrator hose of our manufacture.